

**OPERATING AND MAINTENANCE  
INSTRUCTIONS  
for  
TYPE 1210-B  
UNIT R-C OSCILLATOR  
and  
TYPE 1210-P1  
DETECTOR AND DISCRIMINATOR**

Form 893-A  
June, 1955



**GENERAL RADIO COMPANY**

**275 MASSACHUSETTS AVENUE**

**CAMBRIDGE 39**

**MASSACHUSETTS**

**90 West Street  
New York 6, New York**

**8055 13th Street  
Silver Spring, Maryland**

**York Road and Guernsey Avenue  
Abington, Pennsylvania**

**920 South Michigan Avenue  
Chicago 5, Illinois**

**1000 North Seward Street  
Los Angeles 38, California**

Printed in U.S.A.

## TABLE OF CONTENTS

	Page
Section 1. INTRODUCTION . . . . .	1
1.1 General Description . . . . .	1
1.2 Purpose . . . . .	1
1.3 Controls . . . . .	1
1.4 Connections . . . . .	2
Section 2. THEORY OF OPERATION . . . . .	2
2.1 Oscillator Circuit . . . . .	2
2.2 Automatic Gain Control Circuit . . . . .	3
2.3 Output Amplifier . . . . .	3
Section 3. INSTALLATION . . . . .	4
3.1 Power Supply . . . . .	4
3.2 Accessory Equipment . . . . .	5
Section 4. OPERATING PROCEDURE . . . . .	6
4.1 Frequency Setting . . . . .	6
4.2 Output Systems . . . . .	6
Section 5. SERVICE AND MAINTENANCE . . . . .	7
5.1 General . . . . .	7
5.2 Input Power . . . . .	7
5.3 Removal of Cover . . . . .	9
5.4 Tube Replacement and Adjustments . . . . .	9
5.5 Tube Voltage and Resistance Measurements . . . . .	9
Section 6. PARTS LIST (Type 1210-B Unit R-C Oscillator) . . . . .	14
Section 7. TYPE 1210-P1 DETECTOR AND DISCRIMINATOR . . . . .	15
7.1 Introduction . . . . .	17
7.2 Installation . . . . .	19
7.3 Operating Procedure . . . . .	19
7.4 Applications . . . . .	21
7.5 Service and Maintenance . . . . .	22
7.6 Parts List (Type 1210-P1 Detector and Discriminator) . . . . .	25

## SPECIFICATIONS

### TYPE 1210-B UNIT R-C OSCILLATOR

<b>Frequency Range</b>	20 to 500,000 cps in 5 ranges: 20-200; 200-2000; 2000-20,000; 20,000-200,000; and 50,000-500,000.
<b>Frequency Controls</b>	Range selection switch and 4-in. precision gear-driven dial. Dial has two scales, 2-20 and 50-500, and is geared to a slow-motion knob that covers each decade in approximately 4-1/2 turns.
<b>Frequency Accuracy</b>	±3%.
<b>Output Control</b>	Logarithmic, calibrated 0-50 db.
<b>Output System</b>	3-position panel switch for square-wave, sine-wave low-impedance, or sine-wave high-impedance output.
<b>Low-Impedance Output</b>	0-7v, constant within ±1 db up to 200 kc; output impedance 50 ohms; distortion less than 1% from 200 cps to 20 kc, no load; less than 1.5% over entire frequency range. With 600-ohm load, at 1 kc, distortion is less than 1.5%. Hum is at least 60 db below output voltage level.
<b>High-Impedance Output</b>	0-45v, constant within ±1 db from 200 cps to 200 kc; distortion less than 5% from 200 cps to 200 kc, no load (reduced under load). Output impedance 12,500 ohms. Hum is at least 50 db below max output voltage level.
<b>Square-Wave Output</b>	0-30 v peak to peak; rise time approx 1/4 μsec; overshoot approx 1%; hum is at least 60 db below output voltage level; output impedance 2500 ohms.
<b>Output Terminals</b>	Two jack-top Type 274 binding posts, one grounded to panel.
<b>Tubes</b>	One 6BQ7-A, two 12AU7'S, and one 0B2; all are supplied with instrument.
<b>Power Requirements</b>	6.3 v ac or dc at 1 amp; 300 v dc at 50 ma.
<b>Power Supply</b>	Recommended: Type 1201-A Unit Regulated Power Supply or Type 1203-A Unit Power Supply for operation from 115-v, 50-60 cps power line. Type 1204-B Unit Variable Power Supply also can be used. Type 1202-A Unit Vibrator Power Supply can be operated from either a 6- or 12-v storage battery or from a 115-v, 50-60 cps power line. A matching multipoint connector is supplied for other power supplies.
<b>Mountings</b>	Black-crackle-finish aluminum panel and sides; aluminum cover finished in clear lacquer. The Type 480-P4U3 Panel is available for use with oscillator and power supply combination.
<b>Dimensions</b>	Width: 10-1/2 in., height: 5-3/4 in., depth: 7 in. over-all.
<b>Weight</b>	6-1/4 lb.



Figure 1. Type 1210-B Unit R-C Oscillator with attached Type 1203-A Unit Power Supply.

# TYPE 1210-B

## UNIT R-C OSCILLATOR

### Section 1.

#### INTRODUCTION

1.1 GENERAL DESCRIPTION. The Type 1210-B Unit R-C Oscillator (see Figure 1) is a resistance-tuned oscillator, which combines the standard features of this type of instrument with square-wave output and "sweepability". A standard black-crackle-finished cabinet encloses the simply constructed, compact instrument.

1.2 PURPOSE. Because of the square-wave output possible with the Type 1210-B Unit R-C Oscillator, both low- and high-frequency square-wave tests of transient behavior are possible. Since the instrument can be swept mechanically, frequency characteristics can be recorded either on level recorders or on cathode-ray oscillographs.

1.3 CONTROLS. The following table lists the controls on the panel of the Type 1210-B Unit R-C Oscillator:

<u>Name</u>	<u>Description</u>	<u>Use</u>
FREQUENCY RANGE	5-position rotary switch	Selects frequency range.
DECIBELS	Rotary knob	Varies output level.
SINE WAVES - SQUARE WAVES	3-position rotary switch	Selects sine-wave low-impedance, sine-wave high-impedance, or square-wave output.
None	4-inch circular dial	Selects frequency.

GENERAL RADIO COMPANY

1.4 CONNECTIONS. The following table lists the connections on the Type 1210-B Unit R-C Oscillator.

Connection	Use
Multipoint connector	Power supply connection
Jack-top binding posts (2)	Output terminals

Section 2

THEORY OF OPERATION

2.1 OSCILLATOR CIRCUIT. The oscillator circuit is essentially a series-parallel R-C network. (See Figure 2.) At operating frequency, the voltage from the network is one-third the input voltage, and of the same phase as the input. At frequencies above and below operating frequency, the output and input voltages differ in phase and the attenuation is greater than 3 to 1. When an amplifier of zero phase shift and a gain of at least 3 to 1 is connected from the output to the input of the R-C network, the circuit oscillates. Continuously variable capacitors provide at least a 10-to-1 frequency range, and resistor switching provides five decade ranges. Resistors are deposited-carbon-film type for greater stability.

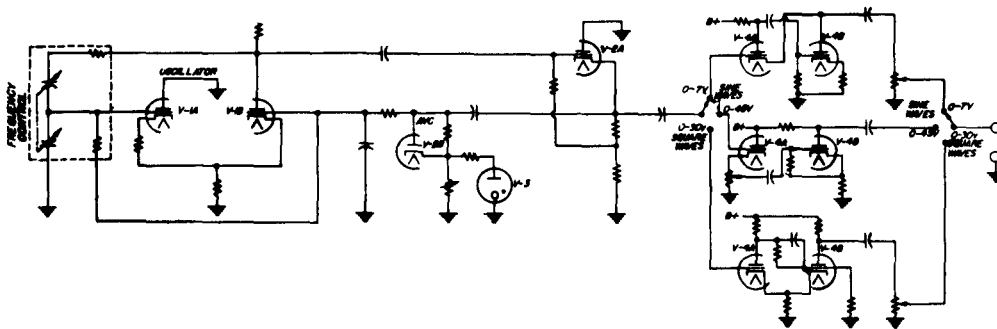

Figure 2. Elementary Schematic Diagram, Type 1210-B Unit R-C Oscillator.

## TYPE 1210-B UNIT R-C OSCILLATOR

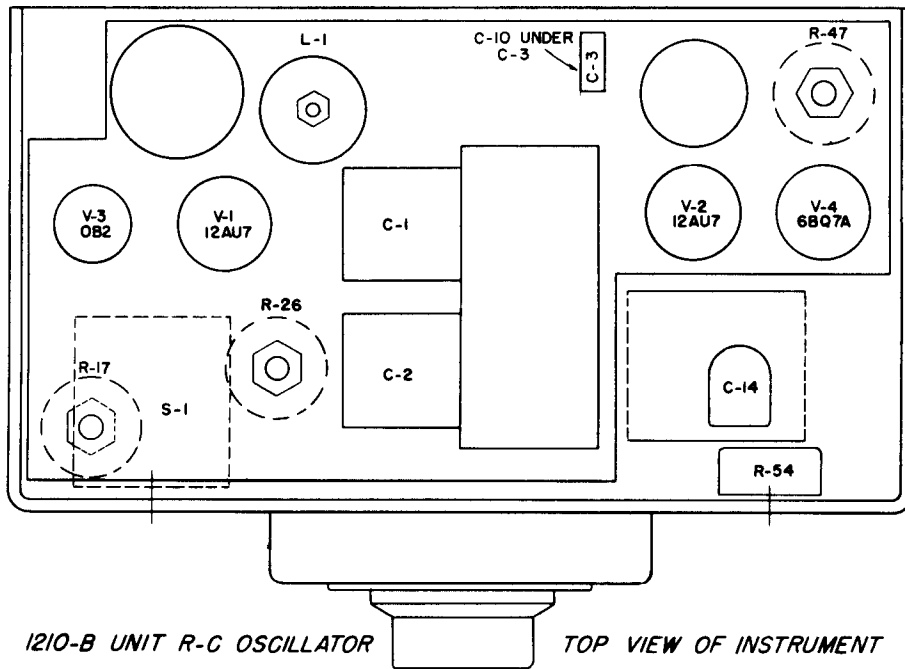

Figure 3. Tube and Adjustment Chart.

2.2 **AUTOMATIC GAIN CONTROL CIRCUIT.** The oscillator output is rectified and compared with a reference voltage. The resultant difference voltage is filtered and fed back to the grids of the oscillator tube to restrict the level of operation and to yield low distortion.

### 2.3 OUTPUT AMPLIFIER.

2.3.1 For 0-7-volt sine-wave output, the amplifier uses a modified cathode-follower circuit for low output impedance.

2.3.2 For 0-45-volt sine-wave output, the output tube is a voltage amplifier with degeneration at the oscillator frequency and with a grid leak to provide d-c bias. High output voltage is thus available at satisfactorily low distortion. As the output load is increased, degeneration is also increased and distortion is reduced.

2.3.3 For square-wave output, a Schmitt circuit is used. This circuit yields excellent square waves with a minimum of components and adjustments. Equality of pulse lengths can be obtained by adjustment of R47 (see Figure 3). Overshoot can be set at about 1% by adjustment of C14. Rise time is normally about a quarter of a microsecond. With a 200-ohm load and a slight readjustment of C14, a rise time of about one-tenth microsecond can be obtained.

GENERAL RADIO COMPANY

Section 3

INSTALLATION

3.1 POWER SUPPLY.

3.1.1 TYPE 1203-A UNIT POWER SUPPLY. When plugged into a Type 1203-A Unit Power Supply (see Figure 1), the Type 1210-B Unit R-C Oscillator is ready for operation from a 115-volt, 50-60-cycle power line. The two units can be firmly and permanently attached together by means of the 10-32 screw and wing nut furnished with the power supply.

3.1.2 TYPE 1201-A UNIT REGULATED POWER SUPPLY. When plugged into a Type 1201-A Unit Regulated Power Supply, the Type 1210-B Unit R-C Oscillator is ready for operation from a 115-volt, 50-60-cycle power line. The plate supply is then regulated with consequent improvement in stability against line-voltage fluctuations.

3.1.3 TYPE 1204-B UNIT VARIABLE POWER SUPPLY. The Type 1210-B Unit R-C Oscillator can also be operated from a Type 1204-B Unit Variable Power Supply, which has a matching multipoint connector for the oscillator connection. The output control of the power supply must be set to limit the operating current to 50 ma dc (as indicated on the power-supply panel meter). The Type 1204-B Unit Variable Power Supply is limited to operation from a 115-volt, 60-cycle power line.

3.1.4 TYPE 1202-A UNIT VIBRATOR POWER SUPPLY. When plugged into the Type 1202-A Unit Vibrator Power Supply, the Type 1210-B Unit R-C Oscillator is ready for operation from either a 115-volt, 50-60-cycle power line or from a storage battery (6- or 12-volt, depending on internal wiring of the power supply). The power supply and oscillator can be firmly and permanently attached together by means of the 10-32 screw and wing nut supplied with the power supply.

3.1.5 OTHER POWER SUPPLIES. When using a power supply other than a Unit Power Supply, connect the multipoint jack connector (supplied with the Type 1210-B Unit R-C Oscillator) to the power supply. Connections are as follows:

<u>Terminal</u>	<u>To</u>
13 and 14	Heaters
15	B+
16	B-

(Terminals 14 and 16 are grounded to the oscillator panel.)



## TYPE 1210-B UNIT R-C OSCILLATOR

### 3.2 ACCESSORY EQUIPMENT.

**3.2.1 SWEEP DRIVE.** The oscillator dial is gear driven from a knob for high-resolution manual control. The knob and the pinion gear can be replaced by the Type 908-P1 or 908-P2 Synchronous Dial Drive. These drives are powered by small synchronous motors, which automatically reverse when their motion in one direction is stopped. Small adjustable stops, furnished with the drives, can be positioned on the oscillator dial to limit the sweep angle to a portion of the frequency range. With this arrangement, a frequency characteristic can be displayed either on a pen-type recorder or on a cathode-ray oscilloscope.

**3.2.2 OSCILLOSCOPE.** For oscilloscope display, the oscillator output must be modified by a discriminator system and rectified to provide the x-axis sweep voltage; the output of the network under test must be rectified to provide the y-axis voltage. A discriminator-rectifier system to perform these functions is provided by the Type 1210-P1 Detector and Discriminator (refer to Section 7). The oscilloscope must have a long-persistence screen, and both of the oscilloscope amplifiers should be uniform in response from dc to at least the lower audio-frequency range. Because of the speed of response, the Type 908-P2 Synchronous Dial Drive should be used, since it is the faster of the two drives.

**3.2.3 RECORDER.** The Type 908-P1 Synchronous Dial Drive can be used with a pen-type recorder that also uses a synchronous motor. Such an instrument is the Model 151-100A Recorder Assembly (Sanborn Company, Cambridge, Mass.). The gain of the recorder is set for adequate deflection; marks are made on the recording paper at appropriate frequencies by operation of a push button on the recorder. Another acceptacle recorder is the Bruel and Kjaer Model BL-2304 Level Recorder (Brush Electronics Company, Cleveland, Ohio). This instrument is attached to the Type 1210-B Unit R-C Oscillator dial by the Model B6-3005 Coupler (Brush). By means of this direct link between oscillator and recorder, it is possible to start and stop the recording without loss of synchronism between oscillator and recorder.

**3.2.4 PULSE GENERATOR.** The Type 1217-A Unit Pulser provides output pulses of excellent quality (0.5  $\mu$ sec rise time) at certain discrete frequencies from 30 cycles to 100 kilocycles. When the Unit Pulser is triggered by the Type 1210-B Unit R-C Oscillator, pulses can be obtained at any frequency over the range up to 100 kilocycles. Connect the 0-45-volt output of the oscillator to the EXTERNAL DRIVE terminals of the Unit Pulser (INPUT switch to EXTERNAL TRIGGER). Set the PULSES PER SECOND switch to a rate the same as, or just below the frequency setting of the Type 1210-B Unit R-C Oscillator.

## Section 4

### OPERATING PROCEDURE

4.1 FREQUENCY SETTING. The outer scale of the direct-reading four-inch dial is used for the lower four frequency ranges on the FREQUENCY RANGE switch (20-200 c, 200-2000 c, 2-20 kc, and 20-200 kc). The inner scale is used for the 50-500-kc range.

#### 4.2 OUTPUT SYSTEMS.

4.2.1 With the output selector switch set at 0-7 v SINE WAVES, the output terminals are connected to the 5000-ohm output control of a modified cathode-follower circuit. When the output control knob (labeled DECIBELS) is turned fully clockwise, the output impedance is very low (about 50 ohms); the load resistance, however, should not be much less than 500 ohms if excessive distortion is to be avoided. Voltage level is about 7 volts. As the output control knob is turned counterclockwise, the output impedance, which depends on this setting, can be as great as 1250 ohms. When the output control knob is below the -5-db point, the distortion will not be excessive even if the load resistance is less than 500 ohms. For high-impedance loads, the change in output level is given in decibels on the plate at the output control knob. The DECIBELS calibration is sufficiently accurate for use over the entire frequency range. Note that when the output control knob is turned fully clockwise, the arrow points to the end of the circumscribed line (about +5 db) and not to 0. At the full-counterclockwise position the residual output is less than 3 millivolts.

4.2.2 With the output switch set at 0-45 v SINE WAVES, the output terminals are connected through an isolating capacitor to the plate circuit of the amplifier stage. The output control is in the grid circuit. The output impedance of 12.5 kilohms is thus independent of the setting of the output control, which affects only the voltage level. A 56-kilohm resistor is connected across the output terminals to provide a leakage path for the isolating (electrolytic) capacitor. When the output control knob is at the full-counterclockwise position, the residual voltage is a function of frequency. Typical readings are: less than 0.1 volt from 100 to 20,000 cycles; less than 0.3 volt down to 20 cycles; as much as 1.5 volts at 500 kilocycles. Because of the residual voltage, the DECIBELS calibration of output control is inaccurate for the 0-45-volt range. There is some degeneration in the output stage, and it increases as the load increases. Therefore, loading reduces the distortion.

4.2.3 With the output switch set at the SQUARE WAVES position, the available output is 30 volts peak-to-peak. The rise time is about 1/4

## TYPE 1210-B UNIT R-C OSCILLATOR

microsecond. The output terminals are connected to the 5000-ohm output control in the plate circuit of the output stage. The output impedance is about 2500 ohms with the control at maximum, and decreases as the control is turned back. The residual voltage, with the control at the full-counterclockwise position, is less than 15 millivolts peak-to-peak. Therefore, if the load impedance is large compared with the output impedance, the DECIBELS calibration of the output control is accurate, even at the lowest settings.

### Section 5

## SERVICE AND MAINTENANCE

5.1 GENERAL. This service information, together with the information given in the foregoing sections, should enable the user to locate and correct ordinary difficulties resulting from normal use.

Major service problems should be referred to our Service Department, which will co-operate as much as possible by furnishing information and instructions as well as by supplying any replacement parts needed.

When notifying our Service Department of any difficulties in operation or service of the instrument, always mention the serial number and type number. Also include in correspondence a complete report of trouble encountered, with specific reference to the numbered paragraphs in the Operating and Maintenance Instructions pertaining to the trouble, as well as any information concerning the use of the instrument and steps taken to eliminate the trouble.

Before returning an instrument or parts for repair, please write to our Service Department, requesting a Returned Material Tag, which includes shipping instructions. Use of this tag will insure proper handling and identification when an instrument or parts are returned for repair. A purchase order covering material returned for repair should also be forwarded to avoid any unnecessary delay.

5.2 INPUT POWER. The input power at a 115-volt, 60-cycle line is about 35 watts when the oscillator is supplied by a Type 1203-A Unit Power Supply.

TABLE 1.

TABLE OF ADJUSTMENTS

PART	CONDITIONS				ADJUST FOR
	FREQUENCY RANGE	DIAL	OUTPUT SWITCH	OUTPUT CONTROL	
R26	200-2000 c	2.5	0-7 v	Clockwise	7.0 v max open-circuit output at 250 c.
R17	200-2000 c	2.5	0-7 v	Clockwise	Minimum 2d-harmonic distortion at no load.
C3, C10	200-2000 c	20	0-7 v	Clockwise	2000 c, 7.0 v (measured with dust cover on).
L1	20-200 kc	20	0-7 v	Clockwise	200 kc (measured with dust cover on).
R47	200-2000 c	10	0-30 v	Clockwise	Square-wave symmetry along time axis.
C14	200-2000 c	10	0-30 v	Clockwise	Slight overshoot (square wave) - less than 1%.

8

GENERAL RADIO COMPANY

## TYPE 1210-B UNIT R-C OSCILLATOR

5.3 REMOVAL OF COVER. To remove the cover, loosen the thumb-screw on the right-hand side of the cabinet.

5.4 TUBE REPLACEMENT AND ADJUSTMENTS. (Refer to Table 1.)

5.4.1 If either the oscillator tube (V1) or the reference-voltage tube (V3) is replaced, the only readjustment usually required is the resetting of R26 for 7.0 volts maximum open-circuit output at 250 cycles. A more complete procedure when V1 is replaced involves setting R17 for minimum distortion while maintaining the output at 7 volts by means of R26.

5.4.2 The trimmer capacitors (C3 and C10) have been set for correct frequency tracking and for flatness of output over the 200-2000-cycle range, with the cover on. Replacement of V1 may require a slight readjustment of C10.

5.4.3 The dust core of L1 has been set for correct frequency calibration at 200 kilocycles (20-200-kilocycle range) with the cover on.

5.4.4 If the output amplifier tube (V4) is replaced, R47 may require readjustment for equality of pulses during square-wave operation. Also, C14 may require resetting to keep overshoot to less than one percent.

5.4.5 The hub of the frequency dial is insulated from the shaft by a polystyrene sleeve, and is grounded to the panel by spring washers. If this ground is incorrectly made, the 60-cycle beat (0-7-volt range) may materially exceed a swing of 0.3 volt.

5.5 TUBE VOLTAGE AND RESISTANCE MEASUREMENTS. Table 2, page 10, gives the normal d-c voltage and d-c resistance from various tube-socket pins to ground. A deviation of 20 percent from any of these values is not necessarily abnormal.

TABLE 2.  
VOLTAGE AND RESISTANCE CHART

TUBE	OUTPUT SWITCH POSITION	PLATE			GRID			CATHODE		
		PIN	VOLTS TO GND	RES TO GND	PIN	VOLTS TO GND	RES TO GND	PIN	VOLTS TO GND	RES TO GND
V1a V1b (12AU7)	ANY ANY	1 6	+215 160	7 k $\Omega$ 12 k $\Omega$	2 7	+40-44* 40	1.5-14 M $\Omega$ * 1.5 M $\Omega$	3 8	+45 42.5	3090 $\Omega$ 2700 $\Omega$
V2a V2b (12AU7)	ANY ANY	1 6	295 40	1 k $\Omega$ 700 k $\Omega$	2 7	114 40	0.3-1 M $\Omega$ * 0.7 M $\Omega$	3 8	120 49	23 k $\Omega$ 15 k $\Omega$
V3 (OB2)	ANY	1,5	155	10.5 k $\Omega$	—	—	—	7	50	6.2 k $\Omega$
V4a V4b V4a V4b V4a V4b (C6Q7A)	0-7 v 0-7 v 0-45 v 0-45 v 0-30 v 0-30 v	1 6 1 6 1 6	290 150 295 90-140† 240 265	1.8 k $\Omega$ $\infty$ 1.8 k $\Omega$ 23 k $\Omega$ 5.7 k $\Omega$ 6.1 k $\Omega$	2 7 2 7 2 7	148 0 26 7-12† 86 80	0.5 M $\Omega$ 57 k $\Omega$ 90 k $\Omega$ 57.5 k $\Omega$ 270 k $\Omega$ 39 k $\Omega$	3 8 3 8 3 8	150 1.5 31 9.5-12† 93 93	$\infty$ 120 $\Omega$ 5 k $\Omega$ 1.5 k $\Omega$ 6.8 k $\Omega$ 6.8 k $\Omega$

## NOTES

- (1) Input resistance of d-c voltmeter must be at least ten times the value listed in the resistance column.  
(2) \* - Depends on position of FREQUENCY RANGE switch.  
(3) † - Depends on position of output control knob.  
(4) Voltage measurements were made with a B supply (PL-1 No. 15 to ground) of 310 volts dc, and a heater supply (PL-1 No. 14 to ground) of 6.3 volts ac.  
(5) Resistance measurements were made with the power supply removed and with the B supply terminals shorted (PL-1 No. 15 to ground).

TYPE 1210-B UNIT R-C OSCILLATOR

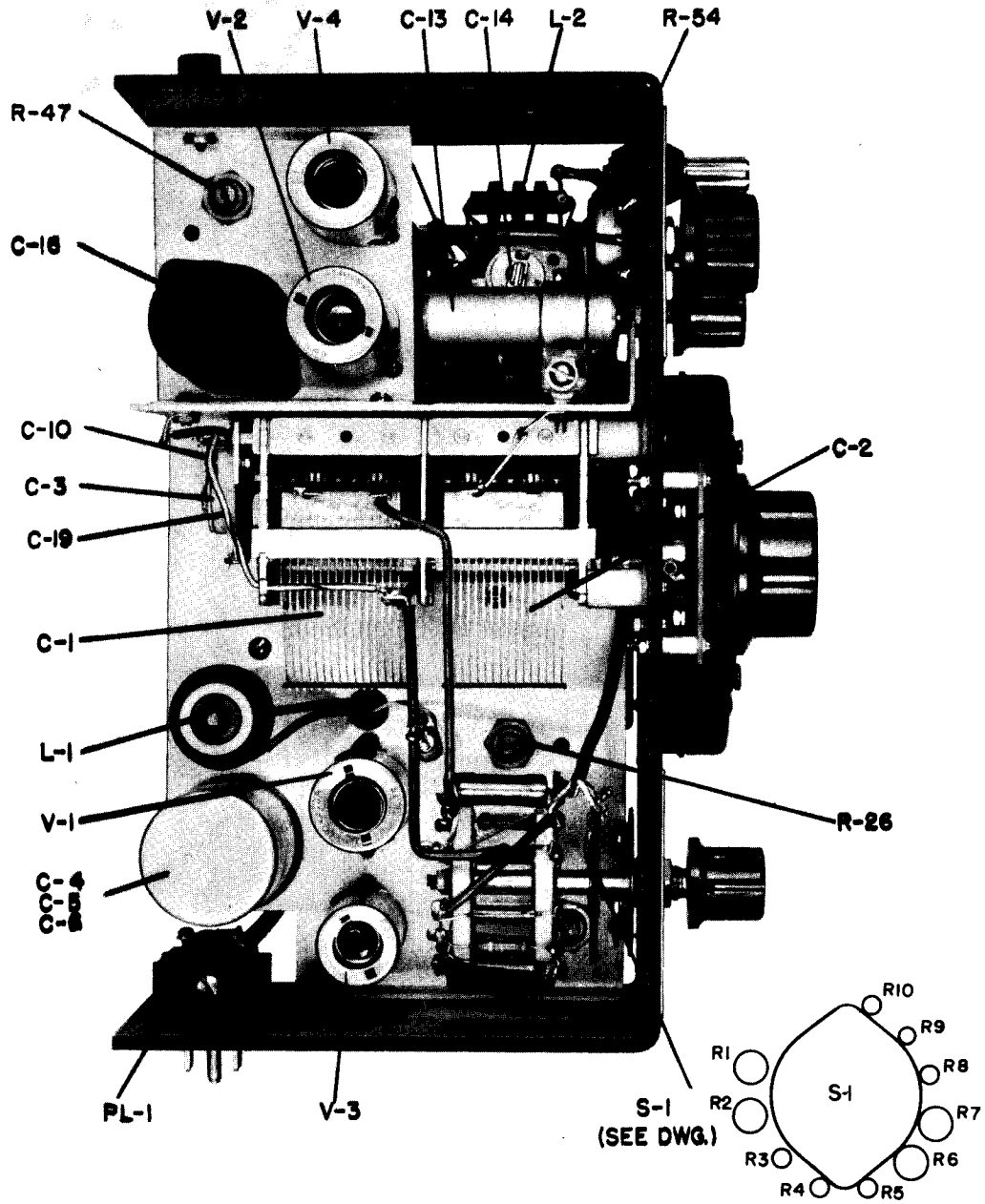

Figure 4. Top Interior View of Type 1210-B Unit R-C Oscillator.

GENERAL RADIO COMPANY

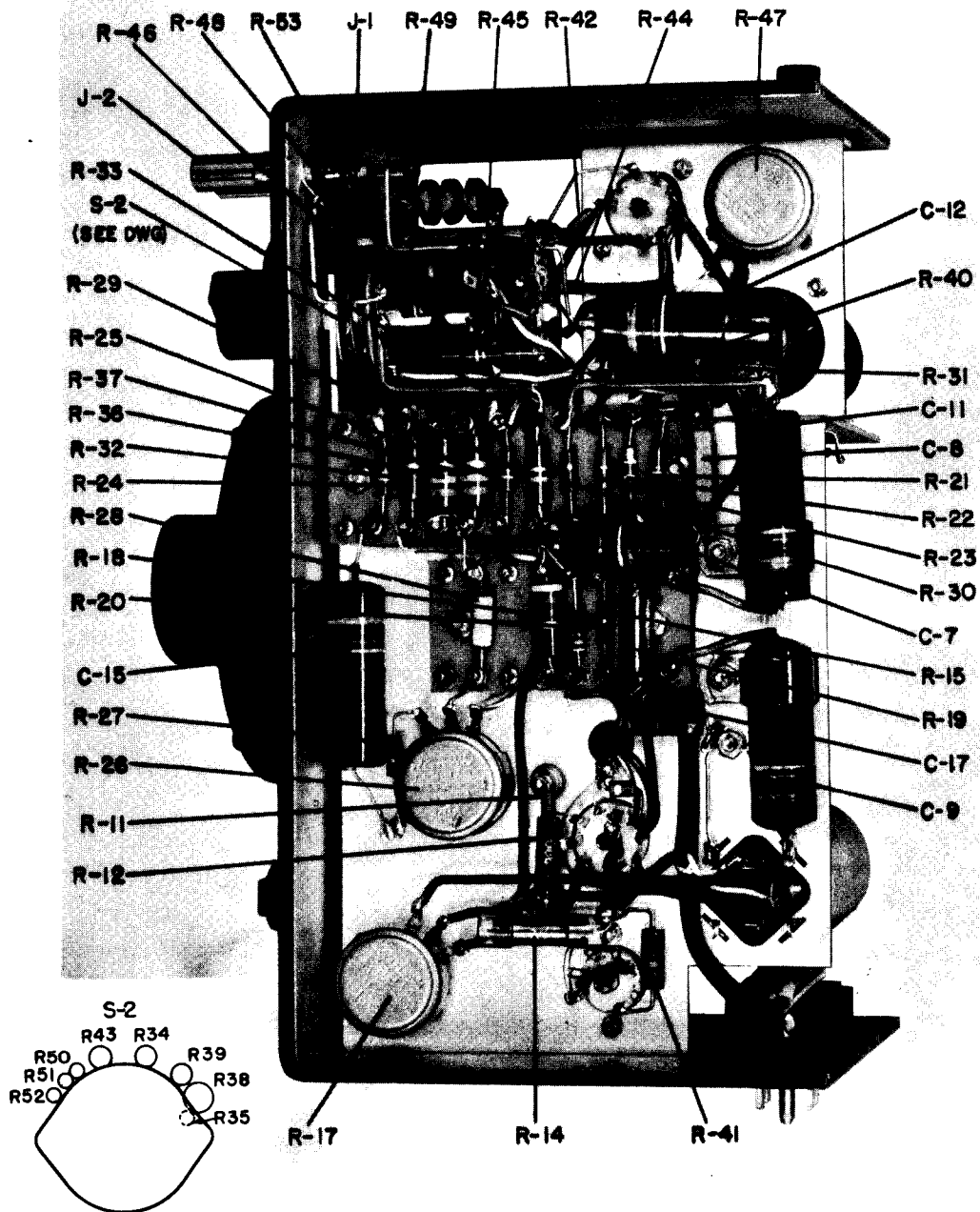
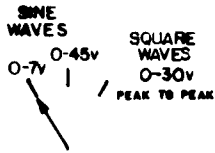

Figure 5. Bottom Interior View of Type 1210-B Unit R-C Oscillator.





### TYPE 1210-B UNIT R-C OSCILLATOR



**NOTES:**

1. ALL RESISTANCES ARE IN OHMS EXCEPT AS OTHERWISE SPECIFIED BY K (1000 OHMS) OR M (1,000,000 OHMS).
2. ALL CAPACITANCES ARE IN MICROFARADS EXCEPT AS OTHERWISE SPECIFIED BY  $\mu\text{f}$  (MICROMICROFARADS).

S-2 ENGRAVING

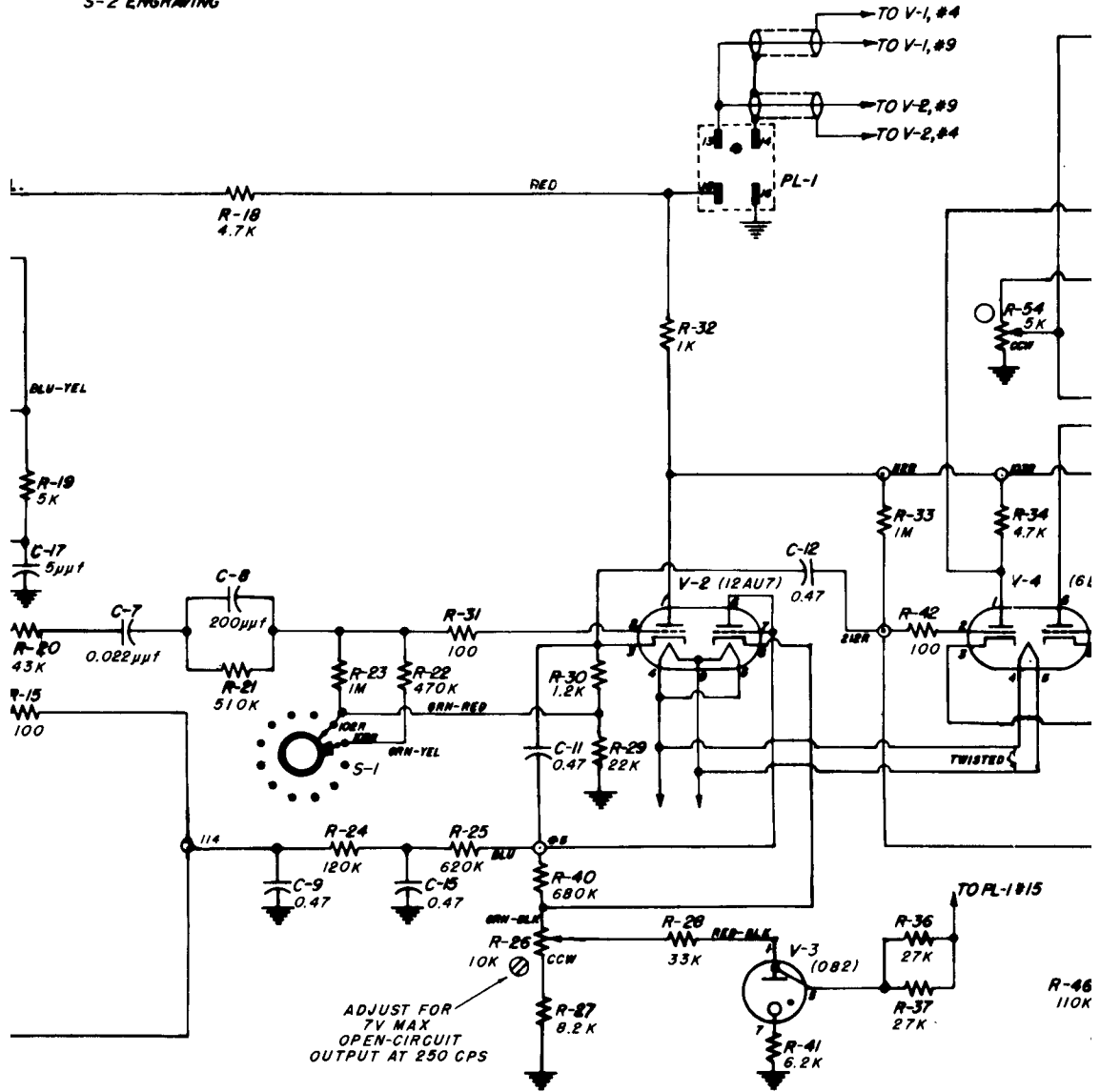
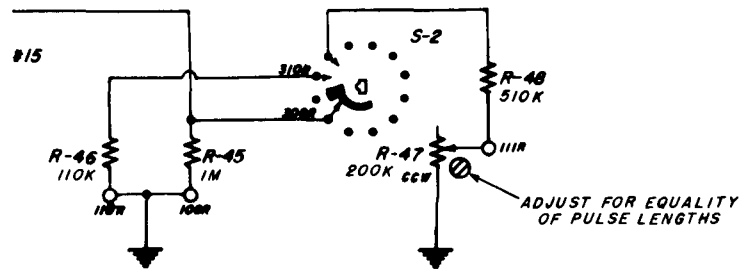
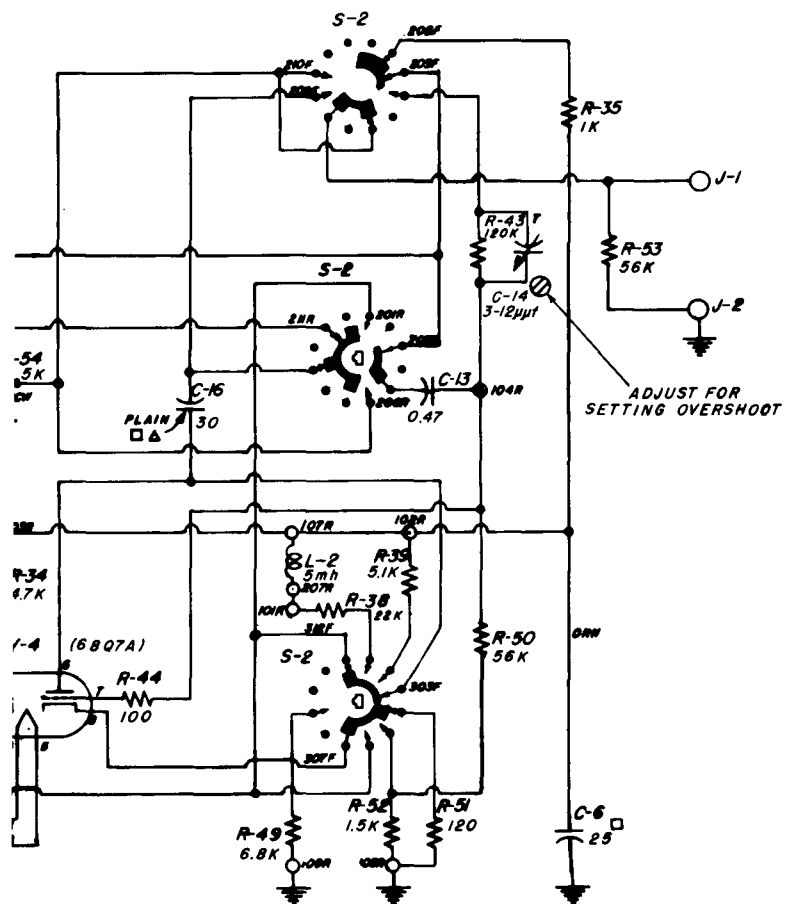

Figure 6. Wiring Diagram for Type 1210-B Unit R-C Oscillator.



## Section 6

### PARTS LIST

#### RESISTORS:

R-1	=	12.8 Megohms	± 1%	1 w	REF-2-2
R-2	=	1.29 Megohms	± 1%	1 w	REF-2-2
R-3	=	125.0 Kilohms	± 1%	1/2 w	REF-2
R-4	=	8.8 Kilohms	± 1%	1/2 w	REF-2
R-5	=	920 Ohms	± 1%	1/2 w	REF-2
R-6	=	12.8 Megohms	± 1%	1 w	REF-2-2
R-7	=	1.29 Megohms	± 1%	1 w	REF-2-2
R-8	=	129 Kilohms	± 1%	1/2 w	REF-2
R-9	=	13 Kilohms	± 1%	1/2 w	REF-2
R-10	=	5.1 Kilohms	± 1%	1/2 w	REF-2
R-11	=	100 Ohms	±10%	1/2 w	REC-20BF
R-12	=	390 Ohms	± 1%	1/2 w	REF-2
R-13	=				
R-14	=	2.7 Kilohms	± 1%	1 w	REF-2-2
R-15	=	100 Ohms	±10%	1/2 w	REC-20BF
R-16	=				
R-17	=	5.0 Kilohms	±10%		POSW-3
R-18	=	4.7 kilohms	±10%	2w	REC-41BF
R-19	=	5 Kilohms	± 1%	1 w	REF-2-2
R-20	=	43 Kilohms	± 5%	1/2 w	REC-20BF
R-21	=	510 Kilohms	± 5%	1/2 w	REC-20BF
R-22	=	470 Kilohms	± 5%	1/2 w	REC-20BF
R-23	=	1 Megohm	±10%	1/2 w	REC-20BF
R-24	=	120 Kilohms	± 5%	1/2 w	REC-20BF
R-25	=	620 Kilohms	± 5%	1/2 w	REC-20BF
R-26	=	10 Kilohms	±10%		POSW-3
R-27	=	8.2 Kilohms	±10%	1/2 w	REC-20BF
R-28	=	33 Kilohms	± 1%	1/2 w	REF-2
R-29	=	22 Kilohms	± 5%	1 w	REC-30BF
R-30	=	1.2 Kilohms	± 5%	1/2 w	REC-20BF
R-31	=	100 Ohms	±10%	1/2 w	REC-20BF
R-32	=	1 Kilohm	±10%	1 w	REC-30BF
R-33	=	1 Megohm	± 5%	1/2 w	REC-20BF
R-34	=	4.7 Kilohms	± 5%	1 w	REC-30BF
R-35	=	1 Kilohm	±10%	1/2 w	REC-20BF

PARTS LIST (Cont)

RESISTORS (Cont)

R-36	=	27 Kiloohms	±10%	2 w	REC-41BF
R-37	=	27 Kiloohms	±10%	2 w	REC-41BF
R-38	=	22 Kiloohms	±10%	2 w	REC-41BF
R-39	=	5.1 Kiloohms	± 5%	1 w	REC-30BF
R-40	=	680 Kiloohms	±10%	1/2 w	REC-20BF
R-41	=	6.2 Kiloohms	±5%	1 w	REC-30BF
R-42	=	100 Ohms	±10%	1/2 w	REC-20BF
R-43	=	120 Kiloohms	± 5%	1 w	REC-30BF
R-44	=	100 Ohms	±10%	1/2 w	REC-20BF
R-45	=	1 Megohm	± 5%	1/2 w	REC-20BF
R-46	=	110 Kiloohms	± 5%	1/2 w	REC-20BF
R-47	=	200 Kiloohms	±10%		POSC-11
R-48	=	510 Kiloohms	± 5%	1/2 w	REC-20BF
R-49	=	6.8 Kiloohms	± 5%	2 w	REC-41BF
R-50	=	56 Kiloohms	± 5%	1/2 w	REC-20BF
R-51	=	120 Ohms	±10%	1/2 w	REC-20BF
R-52	=	1.5 Kiloohms	±10%	1/2	REC-20BF
R-53	=	56 Kiloohms	± 5%	1/2 w	REC-20BF
R-54	=	5 Kiloohms	±10%		POSC-12

CONDENSERS:

C-1	=	603 $\mu\mu\text{f}$	Part of		1210-40
C-2	=	603 $\mu\mu\text{f}$			
C-3	=	5-50 $\mu\mu\text{f}$			COT-12
C-4	=	25 $\mu\text{f}$	450 DCWV		
C-5	=	50 $\mu\text{f}$	Part of		COE-10
C-6	=	25 $\mu\text{f}$			
C-7	=	0.022 $\mu\mu\text{f}$	±10%	600 DCWV	COL-71
C-8	=	200 $\mu\mu\text{f}$	±10	500 DCWV	COM-20B
C-9	=	.47 $\mu\text{f}$	±10%	200 DCWV	COW-27
C-10	=	3-12 $\mu\mu\text{f}$			COT-23
C-11	=	.47 $\mu\text{f}$	±10%	200 DCWV	COW-27
C-12	=	.47 $\mu\text{f}$	±10%	200 DCWV	COW-27
C-13	=	.47 $\mu\text{f}$	±10%	400 DCWV	COW-25
C-14	=	3-12 $\mu\mu\text{f}$			COT-23
C-15	=	.47 $\mu\text{f}$	±10%	200 DCWV	COW-27
C-16	=	30 $\mu\text{f}$	350 DCWV (2-15 $\mu\text{f}$ in //)		COE-53
C-17	=	5 $\mu\mu\text{f}$	±10%	500 DCWV	COM-20B
C-18	=				
C-19	=	15 $\mu\mu\text{f}$	±10%	500 DCWV	COC-21 NPO

**GENERAL RADIO COMPANY**

**PARTS LIST (Cont)**

**SWITCHES:**

<b>S-1</b>	<b>=</b>	<b>Switch</b>	<b>SWRW-98</b>
<b>S-2</b>	<b>=</b>	<b>Switch</b>	<b>SWRW-108</b>

**MISCELLANEOUS:**

<b>J-1</b>	<b>=</b>	<b>Binding Post</b>	<b>BP-5</b>
<b>J-2</b>	<b>=</b>	<b>Binding Post</b>	<b>BP-5</b>
<b>PL-1</b>	<b>=</b>	<b>PLug</b>	<b>CDMP-11-4</b>
<b>L-1</b>	<b>=</b>	<b>1 mh approx.</b>	<b>1210-25</b>
<b>L-2</b>	<b>=</b>	<b>5 mh Approx.</b>	<b>CHA-3-5</b>

**A.T. Nos. Used: 1, , 4, 5**

**GR LETTER DESIGNATIONS**

<b>COC</b> - Capacitor, Ceramic	<b>COW</b> - Capacitor, Wax
<b>COE</b> - Capacitor, Electrolytic	<b>POSC</b> - Resistor, Variable, Composition
<b>COL</b> - Capacitor, Oil	<b>POSW</b> - Resistor, Variable, Wire
<b>COM</b> - Capacitor, Mica	<b>REC</b> - Resistor, Fixed, Composition
<b>COT</b> - Capacitor, Trimmer	<b>REF</b> - Resistor, Fixed, Film

## TYPE 1210-P1 DETECTOR AND DISCRIMINATOR

### SPECIFICATIONS

#### TYPE 1210-P1 DETECTOR AND DISCRIMINATOR

<b>Frequency Range</b>	Approximately linear sweep output voltage from 200 c to 500 kc in seven ranges: 200 to 600 c, 200 to 2000 c, 600 to 6000 c, 2 to 20 kc, 6 to 60 kc, 20 to 200 kc, and 50 to 500 kc.
<b>Sweep Output Voltage</b>	2 v open-circuit per frequency decade, with maximum output from Type 1210-B Unit R-C Oscillator. Output impedance depends on DELAY setting, and varies from 700 k $\Omega$ to 3.2 M $\Omega$ .
<b>Test Voltage</b>	10 v, with maximum output from Type 1210-B Unit R-C Oscillator. Source impedance about 6500 ohms for maximum output setting of TEST VOLTAGE CONTROL, lower for output less than maximum.
<b>Detector Impedance</b>	Approximately 200 k shunted by 20 $\mu\mu\text{f}$ at 1 kc; decreasing to 120 k shunted by 10 $\mu\mu\text{f}$ at 500 kc.
<b>Crystal Diodes</b>	1N34A (five), 1N305 (three). All are supplied.
<b>Terminals</b>	Jack-top binding posts are mounted on standard 3/4-in. spacing.
<b>Mounting</b>	Black-crackle-finish aluminum panel and sides. Aluminum cover finished in clear lacquer. Provision made for attaching to Type 1210-B Unit R-C Oscillator by means of panel screw, and a 10-32 screw with wing nut. Relay Rack Panel Type 480-P4U1 is available for use with the Detector and Discriminator.
<b>Dimensions</b>	Width: 5-1/8 in.; Height: 5-3/4 in.; Depth: 6-3/8 in.
<b>Weight</b>	2-1/2 lb.

GENERAL RADIO COMPANY



Figure 7. Panel View, Type 1210-P1 Detector and Discriminator.



## TYPE 1210-P1 DETECTOR AND DISCRIMINATOR

### Section 7

## TYPE 1210-P1 DETECTOR AND DISCRIMINATOR

### 7.1 INTRODUCTION.

7.1.1 GENERAL. The Type 1210-P1 Detector and Discriminator (see Figure 7) consists of two sections: one providing a d-c output voltage proportional to frequency, the other producing a d-c output voltage proportional to the amplitude of the output voltage of the network under test.

7.1.2 PURPOSE. Used with a Type 1210-B Unit R-C Oscillator and a Type 908-P2 Synchronous Dial Drive, the Type 1210-P1 Detector and Discriminator will provide the necessary voltages for convenient, cathode-ray oscillograph display of the frequency response of a network.

The frequency discriminator is of the capacitance-resistance type, and, with a crystal-diode rectifier and filter, provides an approximately linear d-c voltage proportional to frequency. A frequency range of 200 c to 500 kc is covered in seven ranges.

A separate adjustable test voltage is provided for driving a test network. With a built-in detector and filter circuit, this will provide a d-c output voltage proportional to the amplitude of the output voltage of the test network.

7.1.3 DESCRIPTION. The Type 1210-P1 Detector and Discriminator consists of a diode limiter circuit; a discriminator with rectifier, filter, and delay control; and a test voltage network with detector and filter. A complete circuit diagram is shown in Figure 11.

A self-biased balanced diode limiter circuit controls the amplitude of the voltage applied to the discriminator circuit. The time constant of the limiter circuit is about twenty seconds; amplitude changes occurring more rapidly have very little effect on the discriminator output.

The discriminator covers the frequency range from 200 c to 500 kc in seven ranges: 200 to 600 c, 200 to 2000 c, 600 to 6000 c, 2 to 20 kc, 6 to 60 kc, 20 to 200 kc, and 50 to 500 kc. For the frequency ranges mentioned, the d-c output voltage will be approximately proportional to frequency (see Figure 8).

The symmetrical-type detector circuit is used to rectify the output of a test network, which may be driven by the variable test voltage.

GENERAL RADIO COMPANY

LINEAR

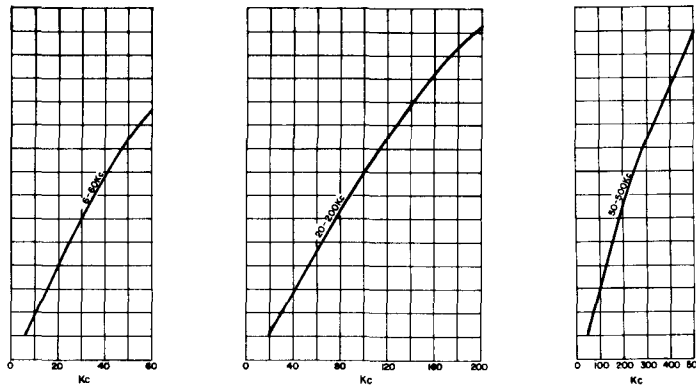
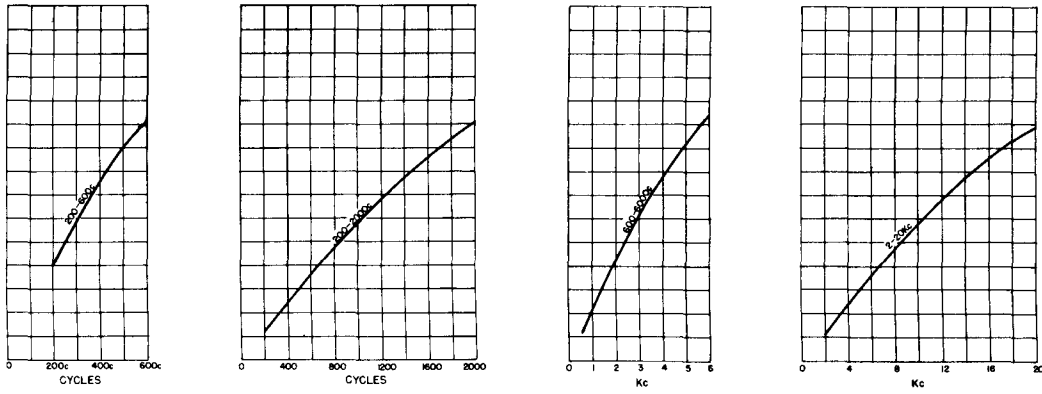

APPROXIMATELY LOGARITHMIC

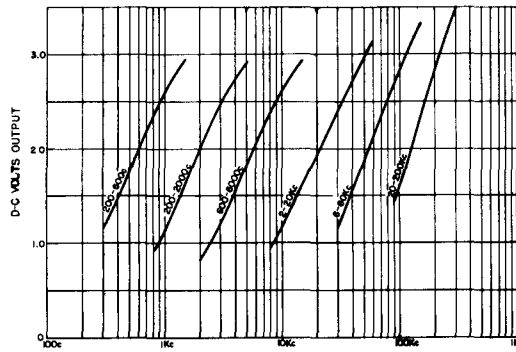

Figure 8. Typical Plots of the Linear and Logarithmic Response Range of the Discriminator Output.

## TYPE 1210-P1 DETECTOR AND DISCRIMINATOR

Two types of diodes are used in series for both the discriminator and detector circuits. A germanium junction diode has excellent linearity at low voltage levels, but poor high-frequency characteristics. The high-frequency characteristic of a point-contact germanium diode is better than the junction type, but is not so linear at low voltages. The combination of the two provides good linearity for the frequency range covered.

### 7.2 INSTALLATION.

7.2.1 FASTENING TO TYPE 1210-B UNIT R-C OSCILLATOR. The Type 1210-P1 Detector and Discriminator may be fastened to the right end of the Type 1210-B Unit R-C Oscillator. Remove the screw and wing nut from the left side of the discriminator, and remove the panel screw from the right rear edge. Align the mounting holes in the two instruments and fasten, using the panel screw for the rear hole and the machine screw and wing nut for the forward hole. The rear panel screw also secures the dust cover of the oscillator.

### 7.3 OPERATING PROCEDURE.

7.3.1 The Type 1210-P1 Detector and Discriminator is usually used with a Type 1210-B Unit R-C Oscillator, but may be used with any oscillator that covers the necessary frequency range and provides the necessary output voltage (about 25 volts).

#### CAUTION

When the output circuit of the Type 1210-B Unit R-C Oscillator is switched, a high transient voltage is developed at the output terminals. Therefore, before connecting the Type 1210-P1 Detector and Discriminator to the Type 1210-B Unit R-C Oscillator, be sure the oscillator is set to the 0-45 v sine-wave position.

7.3.2 Connect the INPUT terminals of the Detector and Discriminator to the Type 1210-B Unit R-C Oscillator by short wire leads. Connect the input of the network to be tested to terminals marked TO DEVICE UNDER TEST, and the output to terminals marked FROM DEVICE UNDER TEST. Connect the VERTICAL DEFLECTION terminals of the Type 1210-P1 to the vertical or Y terminals of the cathode-ray oscillograph set for d-c input. Also, connect the HORIZONTAL DEFLECTION terminals to the d-c horizontal or X terminals of the oscillograph. It is desirable to use shielded leads, such as Type 274-NEO Patch Cords, for these connections to minimize hum pickup.

7.3.3 FREQUENCY CONTROLS. Set the range switch on the Type 1210-P1 to correspond with the frequency range to be covered on the Type 1210-B Unit R-C Oscillator. If a frequency range less than a com-

## GENERAL RADIO COMPANY

plete decade is being swept, higher output sweep voltage is obtained by use of the lowest Detector and Discriminator frequency range consistent with the range being covered. For example, if a frequency range of 3 to 5 kc were being swept, either the 2 to 20 kc range or the 600 to 6000 c range could be used, but greater output would be obtained by use of the 600-6000 c range.

### NOTE

To obtain an approximately logarithmic sweep output voltage, see Paragraph 7.4.2.

7.3.4 OUTPUT CONTROL. Set the Type 1210-B Unit R-C Oscillator to the 0-45 v output position and the output control to maximum.

Adjust the output level for driving the device under test by the control marked TEST VOLTAGE. This is a continuous control that can be used to vary the voltage from zero to a maximum value of about 10 volts for high-impedance loads.

7.3.5 SOURCE AND LOAD IMPEDANCES. The voltage to the device under test is taken from a 10,000-ohm potentiometer. One terminal is grounded. The source impedance varies from approximately 6500 ohms for maximum output to nearly zero for very low output.

The loading of the detector circuit on the device under test is approximately equivalent to 200 kilohms shunted by 20  $\mu\text{f}$  at 1 kc, decreasing to about 120 kilohms shunted by 10  $\mu\text{f}$  at 500 kc.

The VERTICAL DEFLECTION output has a source impedance of about 1.7 megohms.

The source impedance of the HORIZONTAL DEFLECTION output depends on the DELAY control setting, and varies from a minimum of 700 kilohms to a maximum of 3.2 megohms.

7.3.6 OUTPUT VOLTAGE. An open-circuit voltage of at least 2 volts is available at the HORIZONTAL DEFLECTION terminals for each of the decade frequency ranges. The input impedance of the cathode-ray oscillograph should be at least 1 megohm, and the deflection sensitivity of the oscillograph should be at least 0.2 volt per centimeter.

The voltage available at the VERTICAL DEFLECTION terminals will be determined by the magnitude of the voltage applied to the test circuit and the loss in the network itself. The impedance of the vertical input of the oscillograph should be at least 1 megohm.

For satisfactory results the oscillograph should use a cathode-ray tube with a long-persistence screen.

## TYPE 1210-P1 DETECTOR AND DISCRIMINATOR

### 7.4 APPLICATIONS.

#### 7.4.1 ELECTRICAL TESTS.

7.4.1.1 A visual display of frequency characteristics may be obtained of filters, transformers, and other networks with amplitude characteristics that vary with frequency.

If a synchronous dial drive such as the Type 908-P2 Dial Drive is used to drive the Type 1210-B Unit R-C Oscillator, one may observe the effect of changes made in the network as the frequency is swept through the desired range. Adjustment of I-F transformers, especially when overcoupled, is simplified by visual observation.

Manual adjustment of the oscillator frequency makes it possible to mark a frequency scale on the face of the oscillograph tube. If there is a level change in the voltage from the diode limiter circuit because of variations in oscillator output, an apparent error in the frequency scale calibration will result. This will not happen where there is no great change in the output voltage of the oscillator for the frequency range covered, or where a limited frequency range is swept.

In the same manner an amplitude scale may be calibrated, thus simplifying the adjustment of a filter network with respect to cut-off frequencies, amplitude of ripple in pass band, etc.

Since there is no blanking of the horizontal retrace, a double trace will be observed with some networks. This might be the case when a high-Q circuit is swept rapidly.<sup>1</sup> A DELAY control (R10), accessible from the front panel, is adjusted by means of a screw driver for best coincidence of the two sweep traces.

Since the setting of the DELAY control affects the magnitude of the output voltage, readjustment of the horizontal centering control of the cathode-ray oscillograph is usually necessary.

7.4.2 LOGARITHMIC SWEEP VOLTAGE. The frequency ranges marked on the range switch normally provide a reasonably linear sweep voltage. Approximately logarithmic sweep operation may be obtained for the fol-

---

1. Marique, Jean, "The Response of RLC Resonant Circuits of EMF of Sawtooth Varying Frequency", Proc. IRE, Vol. 40, No. 8, pp. 945-950, August, 1952.

---

**GENERAL RADIO COMPANY**

lowing frequency ranges when the range switch is set as indicated (see Figure 8):

<u>Approximately Logarithmic Sweep Range</u>	<u>Range Switch</u>
300 - 1200 c	200 - 600 c
800 - 5000 c	200 - 2000 c
2 - 15 kc	600 - 6000 c
8 - 60 kc	2 - 20 kc
30 - 200 kc	6 - 60 kc
90 - 300 kc	20 - 200 kc

**7.4.3 DETECTOR LINEARITY.** The diode detector circuit is essentially linear at input levels of 2 or more volts. The characteristic is square law at input levels up to approximately 0.5 volt.

**7.5 SERVICE AND MAINTENANCE.**

**7.5.1 GENERAL.** (Refer to Paragraph 5.1.)

**7.5.2 REMOVAL OF COVER.** To remove the U-shaped dust cover, loosen the panel screw near the rear right edge of the instrument and slide off the dust cover.

When the screw at the upper right rear corner is removed, the etched circuit plate can be swung back on its hinges, exposing components on the bottom side.

**7.5.3 TROUBLE-SHOOTING.** If the Type 1210-P1 Detector and Discriminator becomes inoperative, make the following simple checks before removing the instrument from its case.

**7.5.3.1 No Output From Horizontal and Vertical Deflection Terminals.**

**7.5.3.1.1** Be sure that the Type 1210-P1 Detector and Discriminator and the oscillator are set to the same frequency ranges unless logarithmic sweep ranges are being used. (See Paragraph 7.4.2.) Check to see that output is available from the oscillator. See that there is a connection between the output terminals of the oscillator and the input of the Detector and Discriminator. If there is output available from the oscillator, and the connections between the oscillator and the Type 1210-P1 Detector and Discriminator are normal, check the diode rectifiers.

**7.5.3.1.2 Diode Checks.** Two types of diodes are used, the 1N34A, which is a point-contact germanium diode; and the 1N305, which is a germanium junction diode.

An ohmmeter may be used to check the front and back resistances of the diodes. The front resistance of the 1N34A diodes will be approx-

## TYPE 1210-P1 DETECTOR AND DISCRIMINATOR

imately 100 ohms, that of the 1N305 about 30 ohms. These values will depend on the voltage applied to the diodes. It is desirable that not more than 50 ma dc be permitted to flow through the diodes. Some ohmmeters on the low multiplier ranges will permit current greatly in excess of this value. The higher multiplier ranges will usually restrict the current to safe values.

The back resistance of the 1N34A will usually be greater than 100 kilohms. Measurement of the 1N305 back resistance will be more difficult with an ordinary ohmmeter, as the values will be the order of 10 to 20 megohms depending on applied voltage.

**7.5.3.2 No Output From Vertical Deflection Terminals.** Make sure that the TEST VOLTAGE control is not set to minimum output. Check to see that the device under test is not introducing excessive loss. The oscillator and the discriminator and detector unit should be set to sweep the frequency range required by the device under test.

---

GENERAL RADIO COMPANY

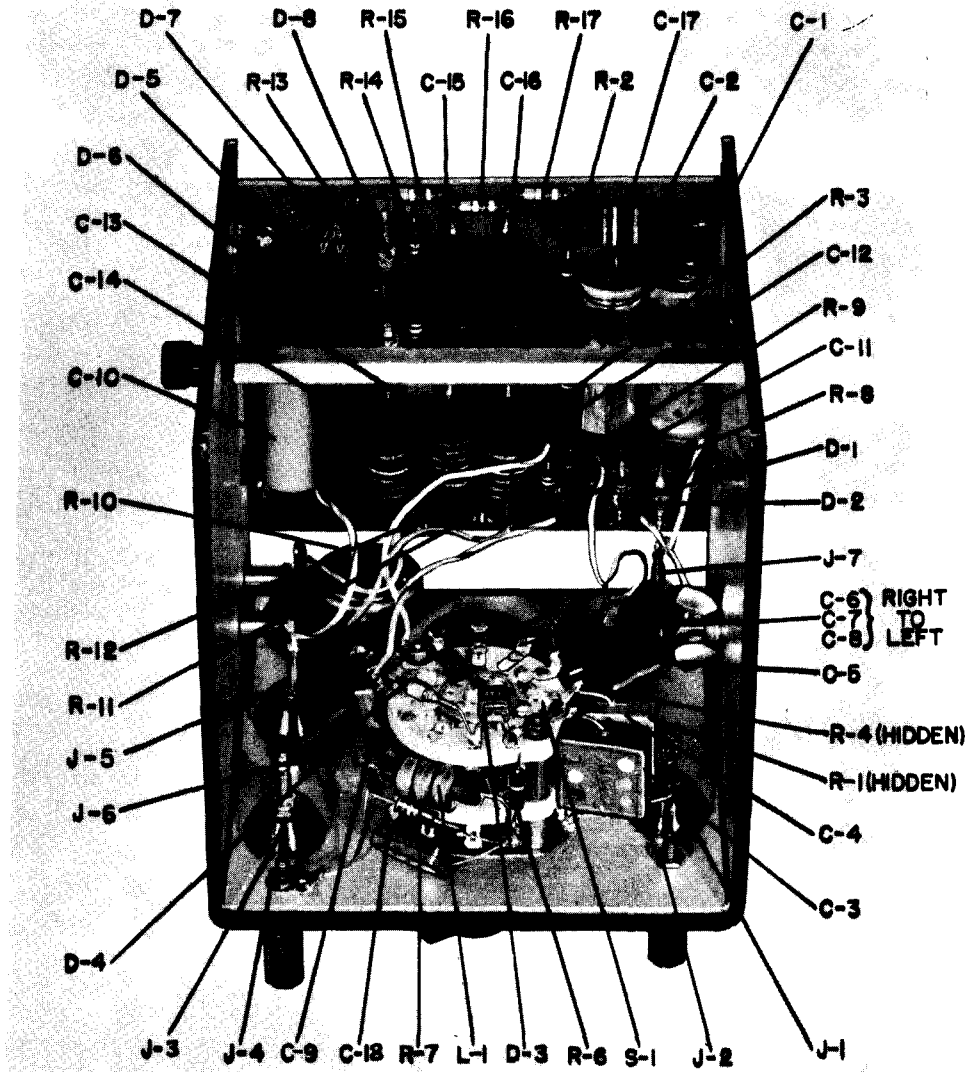

Figure 9. Top Interior View of Type 1210-P1 Detector and Discriminator.



TYPE 1210-P1 DETECTOR AND DISCRIMINATOR

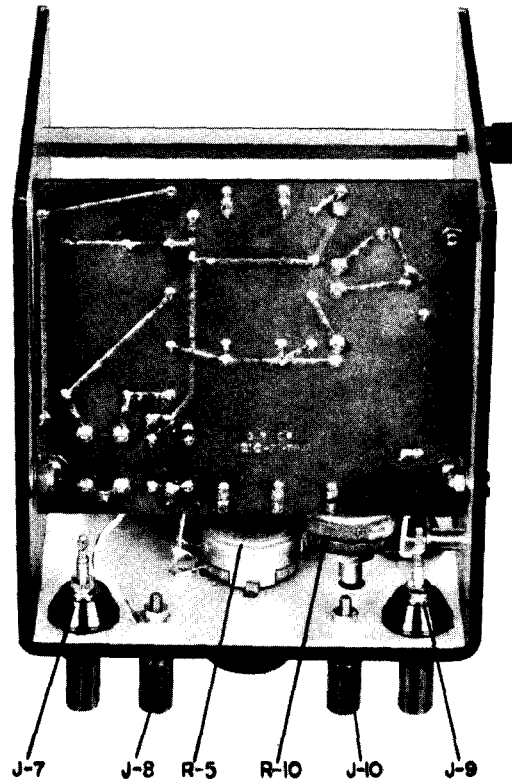

Figure 10. Bottom Interior View of Type 1210-P1 Detector and Discriminator.

7.6 PARTS LIST.

RESISTORS:

R-1 = 33 kilohms	± 5%	1/2 watt	REC-20BF
R-2 = 220 kilohms	± 5%	1/2 watt	REC-20BF
R-3 = 220 kilohms	± 5%	1/2 watt	REC-20BF
R-4 = 10 kilohms	± 5%	1/2 watt	REC-20BF
R-5 = 10 kilohms	±10%		POSC-12
R-6 = 20 kilohms	± 5%	1/2 watt	REC-20BF
R-7 = 47 kilohms	± 5%	1/2 watt	REC-20BF
R-8 = 150 kilohms	± 5%	1/2 watt	REC-20BF
R-9 = 240 kilohms	± 5%	1/2 watt	REC-20BF
R-10 = 2.5 megohms	±20%		POSC-11
R-11 = 180 kilohms	± 5%	1/2 watt	REC-20BF

GENERAL RADIO COMPANY

RESISTORS (Cont)

R-12= 120 kilohms	± 5%	1/2 watt	REC-20BF
R-13= 240 kilohms	± 5%	1/2 watt	REC-20BF
R-14= 270 kilohms	± 5%	1/2 watt	REC-20BF
R-15= 470 kilohms	± 5%	1/2 watt	REC-20BF
R-16= 470 kilohms	± 5%	1/2 watt	REC-20BF
R-17= 470 kilohms	± 5%	1/2 watt	REC-20BF

CONDENSERS:

C-1 = 100 $\mu$ f		25 DCWV	COE-35
C-2 = 100 $\mu$ f		25 DCWV	COE-35
C-3 = .0068 $\mu$ f	± 5%	300 DCWV	COM-35B
C-4 = .002 $\mu$ f	± 5%	500 DCWV	COM-30B
C-5 = 680 $\mu$ f	± 5%	300 DCWV	COM-20B
C-6 = 200 $\mu$ f	± 5%	500 DCWV	COM-20B
C-7 = 68 $\mu$ f	± 5%	500 DCWV	COM-20B
C-8 = 20 $\mu$ f	± 5%	500 DCWV	COM-20B
C-9 = 6.8 $\mu$ f	± 5%	500 DCWV	COM-20B
C-10 = 1 $\mu$ f	±10%	100 DCWV	COM-17
C-11 = 6.8 $\mu$ f	± 5%	500 DCWV	COM-20B
C-12 = .022 $\mu$ f	±10%	600 DCWV	COL-71
C-13 = .022 $\mu$ f	±10%	600 DCWV	COL-71
C-14 = .022 $\mu$ f	±10%	600 DCWV	COL-71
C-15 = .01 $\mu$ f	±10%	600 DCWV	COL-71
C-16 = .01 $\mu$ f	±10%	600 DCWV	COL-71
C-17 = .01 $\mu$ f	±10%	600 DCWV	COL-71
C-18 = 6.8 $\mu$ f	± 5%	500 DCWV	COM-20B

SWITCHES:

S-1 = SWRW-124

MISCELLANEOUS:

J-1 = BP-5	D-1 = IN34-A
J-2 = BP-10,11/16	D-2 = IN34-A
J-3 = BP-5	D-3 = IN305
J-4 = BP-10,11/16	D-4 = IN34-A
J-5 = BP-5	D-5 = IN34-A
J-6 = BP-10,11/16	D-6 = IN305
J-7 = BP-5	D-7 = IN305
J-8 = BP-10,11/16	D-8 = IN34-A
J-9 = BP-5	
J-10 = BP-10,11/16	L-1 = 2.5 mh ±10% 1210-P1-201

Note: See Parts List for Type 1210-B Unit R-C Oscillator for GR letter designations.

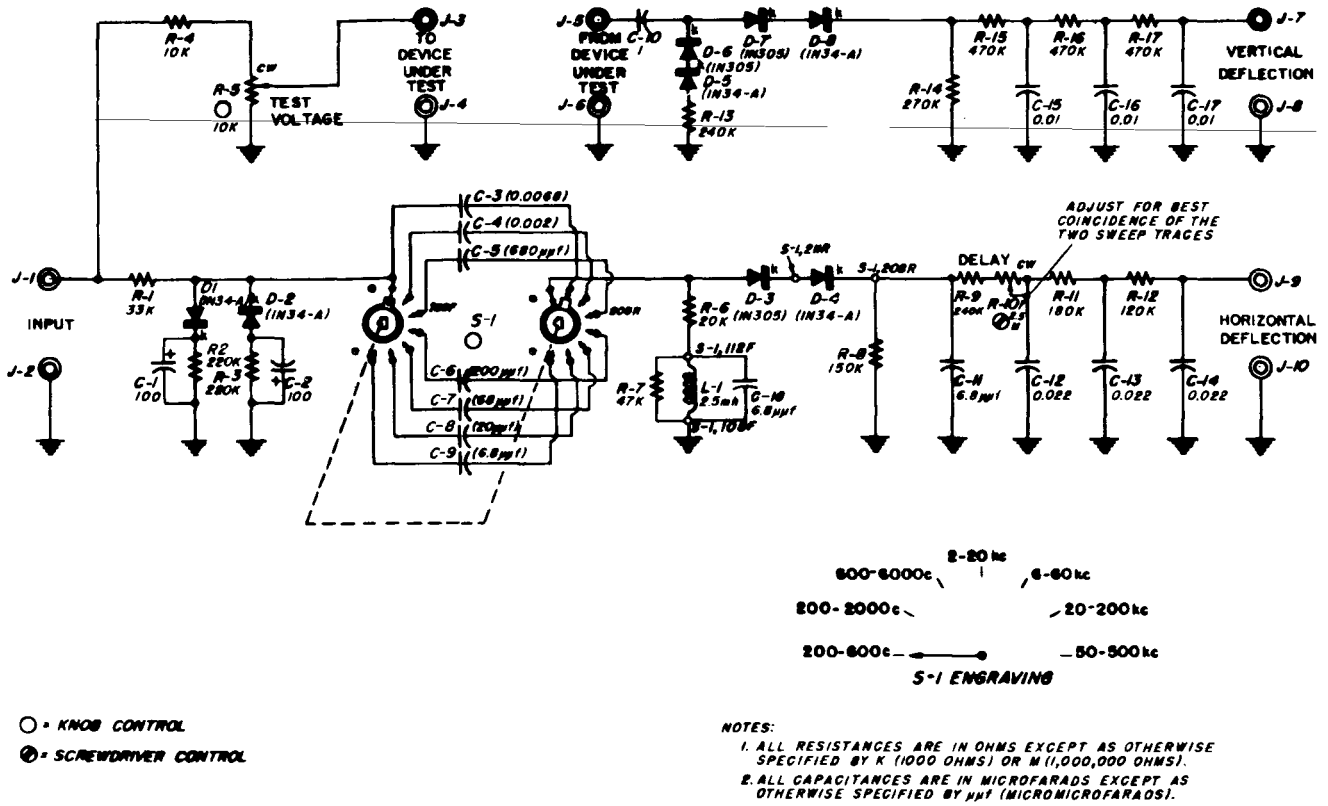

Figure 11. Wiring Diagram for Type 1210-P1 Detector and Discriminator.